



Operating Manual

Table of Content

1. INFORMATION ON THIS DOCUMENT	5
1.1 VALIDITY	5
1.2 TARGET GROUP	5
1.3 CONTENT AND STRUCTURE OF THIS DOCUMENT	5
1.4 DECLARATION OF CONFORMITY	5
1.5 LEVELS OF WARNING MESSAGES	6
1.6 SYMBOLS IN THE DOCUMENT	6
1.7 DESIGNATION IN THE DOCUMENT	6
2. SAFETY	7
2.1 INTENDED USE	7
2.2 IMPORTANT SAFETY INSTRUCTIONSE	7
2.2.1 <i>Battery Pack Leakage</i>	7
2.2.2 <i>Firefighting Measures</i>	8
2.2.3 <i>Battery Packs Handling and Storage Guide</i>	8
2.2.4 <i>Warning of Electric Shock</i>	9
2.2.5 <i>Warning of Overvoltage</i>	9
2.2.6 <i>Caution of Weight</i>	9
2.2.7 <i>Notice of Property Damage</i>	10
3. ENERGY STORAGE SYSTEM OVERVIEW	10
3.1 ENERGY STORAGE SYSTEM DESCRIPTION	10
3.2 SYMBOL ON THE SYSTEM	12
4. INSTALLATION	13
4.1 REQUIREMENTS FOR INSTALLATION	13
4.1.1 <i>Requirements for Installation Location</i>	13
4.1.2 <i>Installation Tools</i>	14
4.1.3 <i>Safety Gear</i>	14
4.2 INSTALLATION	15
5. ELECTRICAL CONNECTION	16
5.1 OVERVIEW OF THE CONNECTION AREA	16
5.1.1 <i>Connection Area View</i>	16
5.2 CONNECTION DIAGRAM	17
5.2.1 <i>One Battery Cabinet</i>	17
5.2.2 <i>Two Battery Cabinets</i>	17
5.2.3 <i>Three Battery Cabinets</i>	18

5.3	DC CONNECTION	18
6.	COMMISSION	19
6.1	SWITCHING ON THE ENERGY STORAGE SYSTEM	19
6.2	SWITCH ON AND COMMISSION INVERTER	20
6.3	SWITCHING ON THE ENERGY STORAGE SYSTEM (WITH INVERTER)	21
7.	DECOMMISSIONING	22
7.1	SWITCHING OFF THE ENERGY STORAGE SYSTEM (WITH INVERTER)	22
7.2	THE WHOLE PROCEDURE OF DECOMMISSIONING	23
8.	EXTENSION	24
8.1	EXTENSION BATTERY PACK	24
8.2	EXTENSION BATTERY CABINET	25
9.	TROUBLESHOOTING	26
9.1	ENERGY STORAGE SYSTEM BEHAVIOR UNDER FAULT CONDITIONS	26
9.2	INVERTER CANNOT DETECT BATTERY INFORMATION	27
9.3	ERROR EVENT	27
10.	MAINTENANCE AND STORAGE	28
11.	DISPOSAL OF ENERGY STORAGE SYSTEM	29
12.	TECHNICAL DATA	29
12.1	5 CON-LVS	29
12.2	10 CON-LVS	30
13.	CONTACT INFORMATION	31

Legal Provisions

All the information in this document is the property of Shandong King Polaris New Energy Stock CO., LTD. No part of this document could be reproduced in any way for business use. Internal use is allowed.

Shandong King Polaris New Energy Stock CO., LTD makes no representations or warranties express or implied, with respect to this document or any of the equipment and/or software it may describe, including (with no limitation) any implied warranties of utility, merchantability, or fitness for any particular purpose. All such representations or warranties are expressly disclaimed. Neither Shandong King Polaris New Energy Stock CO., LTD nor its distributors or dealers shall be liable for any indirect, incidental, or consequential damages under any circumstances.

The exclusion of implied warranties may not apply in all cases under some statutes, and thus the above exclusion may not apply.

This document does not replace and is not intended to replace any local, state, provincial, federal, or national laws, regulations, or codes applicable to the installation, electrical safety, and use of the energy storage system. Shandong King Polaris New Energy Stock CO., LTD assumes no responsibility for the compliance or noncompliance with such laws or codes in connection with the installation of the energy storage system.

Specifications are subject to change without notice. Every effort has been made to make this document complete, accurate, and up to date. However, Shandong King Polaris New Energy Stock CO., LTD may need to make some improvements under certain circumstances without advance notice. Shandong King Polaris New Energy Stock CO., LTD shall not be responsible for any loss caused CONCENPOWER this document, including, but not limited omissions, errors, typographical errors, arithmetical errors, or listing errors in this document. All trademarks are recognized.

Limited Warranty

You can download the latest Limited Warranty from the Internet at www.concenpower.com.

Shandong King Polaris New Energy Stock CO., LTD

1. Information on this document

1.1 Validity

This document is valid for the product of Rack-mounted Parallel System 5 kWh (Model: 5 CON-LVS), Rack-mounted Parallel System 10 kWh (Model: 10 CON-LVS).

1.2 Target group

The instructions in this document may only be performed CONCENPOWER qualified persons who must have the following skills:

- Knowledge of how batteries work and are operated
- Knowledge of how an inverter works and is operated
- Knowledge of, and adherence to the locally applicable connection requirements, standards, and directives
- Knowledge of, and adherence to this document and the associated system documentation, including all safety instructions
- Training in dealing with the hazards associated with the installation and operation of electrical equipment and batteries
- Training in the installation and commissioning of electrical equipment

Failure to do so will make any manufacturer's warranty, guarantee or liability null, and void unless you can prove that the damage was not due to non-compliance.

1.3 Content and structure of this document

This document contains safety information and instructions, scope of delivery, system overview, installation, electrical connection, commissioning, decommissioning, expansion, troubleshooting, maintenance and storage, disposal, and technical data. Please finish reading this document before taking any actions on the energy storage system.

1.4 Declaration of Conformity

The energy storage system described in this document complies with the applicable European directives. The certificate is available in the download area at www.concenpower.com.

1.5 Levels of Warning Messages

The following levels of warning messages may occur when handling the energy storage system.

DANGER

Indicates a hazardous situation which, if not avoided, will result in death or serious injury.

WARNING

Indicates a hazardous situation which, if not avoided, could result in death or serious injury.

CAUTION

Indicates a hazardous situation which, could result in minor or moderate injury

NOTE

Indicates a situation which, if not avoided, can result in property damage.

1.6 Symbols in the Document

QUALIFIED PERSON

Sections describing activities to be performed CONCENPOWER qualified persons only.

1.7 Designation in the Document

Designation in this document	Complete designation
Energy storage system (Also called Battery system)	CONCENPOWER Rack-mounted energy storage system
BMS	Battery management system
BMU	Battery management unit
SOC	State of charge

2. Safety

2.1 Intended Use

The energy storage system is for residential and works, with a photovoltaic system. It is a high capacity LiFePO₄ battery storage system, with a management control unit on itself. It could be operated in on-grid, off-grid and backup modes with compatible inverters.

The energy storage system must only be used as stationary equipment.

The energy storage system is suitable for indoor and outdoor use under the conditions mentioned in Section 5.1.

The energy storage system is not suitable for supplying life-sustaining medical devices. Please ensure that no personal injury would lead due to the power outage of the energy storage system.

Alterations to the energy storage system, e.g., changes or modifications are not allowed unless the written permission of CONCENPOWER is achieved. Unauthorized alterations will void the guarantee and warranty claims. CONCENPOWER shall not be held liable for any damage caused by such changes. The type of label should always be attached to the energy storage system.

2.2 IMPORTANT SAFETY INSTRUCTIONSE

The energy storage system has been designed and tested in accordance with international safety requirements. However, in order to prevent personal injury and property damage and ensure long-term operation of the energy storage system, please do read this section carefully and observe all safety information at all times.

2.2.1 Battery Pack Leakage

If the battery packs leak electrolytes, contact with the leaking liquid or gas should be avoided. The electrolyte is corrosive, and the contact may cause skin irritation and chemical burns. If one is exposed to the leaked substance, do these actions:

Inhalation: Evacuate the contaminated area and seek medical help immediately.

Eye contact: Rinse eyes with flowing water for 15 minutes and seek medical help immediately.

Skin contact: Wash the affected area thoroughly with soap and water and seek medical help immediately.

CONCENPOWER Co., Ltd.

Ingestion: Induce vomiting and seek medical help immediately.

2.2.2 Firefighting Measures

The battery packs may catch fire when it is put into the fire. In case of a fire, please make sure that an ABC or carbon dioxide extinguisher is nearby. Water cannot be used to extinguish the fire. Full protective clothing and self-contained breathing apparatus are required for the firefighters to extinguish the fire.

Full protective clothing and self-contained breathing apparatus are required for the firefighters to extinguish the fire.

2.2.3 Battery Packs Handling and Storage Guide

- The battery packs and its components should be protected from damage when transporting and handling.
- Do not impact, pull, drag, or step on the battery packs.
- Do not insert unrelated objects into any part of the battery packs.
- Do not throw the battery pack into a fire.
- Do not soak the battery packs in water or seawater.
- Do not expose to strong oxidizers.
- Do not short circuit the battery packs.
- The battery packs cannot be stored at high temperatures (more than 50°C).
- The battery packs cannot be stored directly under the sun.
- The battery packs cannot be stored in a high humidity environment.
- Do not use the battery packs if it is defective, or appears cracked, broken or otherwise damaged, or fails to operate.
- Do not attempt to open, disassemble, repair, tamper with, or modify the battery packs. The battery packs are not user-serviceable.
- Do not use cleaning solvents to clean the battery packs.

2.2.4 Warning of Electric Shock

DANGER

Danger to life due to electric shock when live components or DC cables are touched. The DC cables connected to an inverter may be live. Touching live DC cables results in death or serious injury due to electric shock.

- Disconnect the energy storage system and inverter from voltage sources and make sure it cannot be reconnected before working on the device.
- Do not touch non-insulated parts or cables.
- Do not remove the terminal block with the connected DC conductors from the slot under load.
- Wear suitable personal protective equipment for all work on the energy storage system.
- Observe all safety information of the inverter manufacturer.

2.2.5 Warning of Overvoltage

DANGER

Danger to life due to electric shock in case of overvoltage and if surge protection is missing. Overvoltage (e. g. in the event of a flash of lightning) can be further conducted into the building and to other connected devices in the same network via the network cables or other data cables if there is no surge protection. Touching live parts and cables results in death or lethal injuries due to electric shock.

- Ensure that all devices in the same network and the inverter are integrated into the existing surge protection.
- When laying the network cables or other data cables outdoors, it must be ensured that a suitable surge protection device is provided at the transition point of the cable from the energy storage system or the inverter outdoors to the inside of a building.

2.2.6 Caution of Weight

CAUTION

Risk of injury due to weight of the battery pack. Injuries may result if the battery pack is lifted incorrectly or dropped while being transported or installed.

- Transport and lift the battery pack carefully. Take the weight of the battery pack into account.
- Wear suitable personal protective equipment for all work on the energy storage system.

2.2.7 Notice of Property Damage

NOTE

Damage to the BMU due to sand, dust and moisture ingress Sand, dust and moisture penetration can damage the BMU and impair its functionality.

- Only open the BMU if the humidity is within the thresholds and the environment is free of sand and dust.

NOTE

Damage to the energy storage system due to under voltages

- If the energy storage system doesn't start at all, please contact CONCENPOWER local after-sales service within 48 hours. Otherwise, the battery could be permanently damaged.

3. Energy storage system overview

3.1 Energy storage system Description

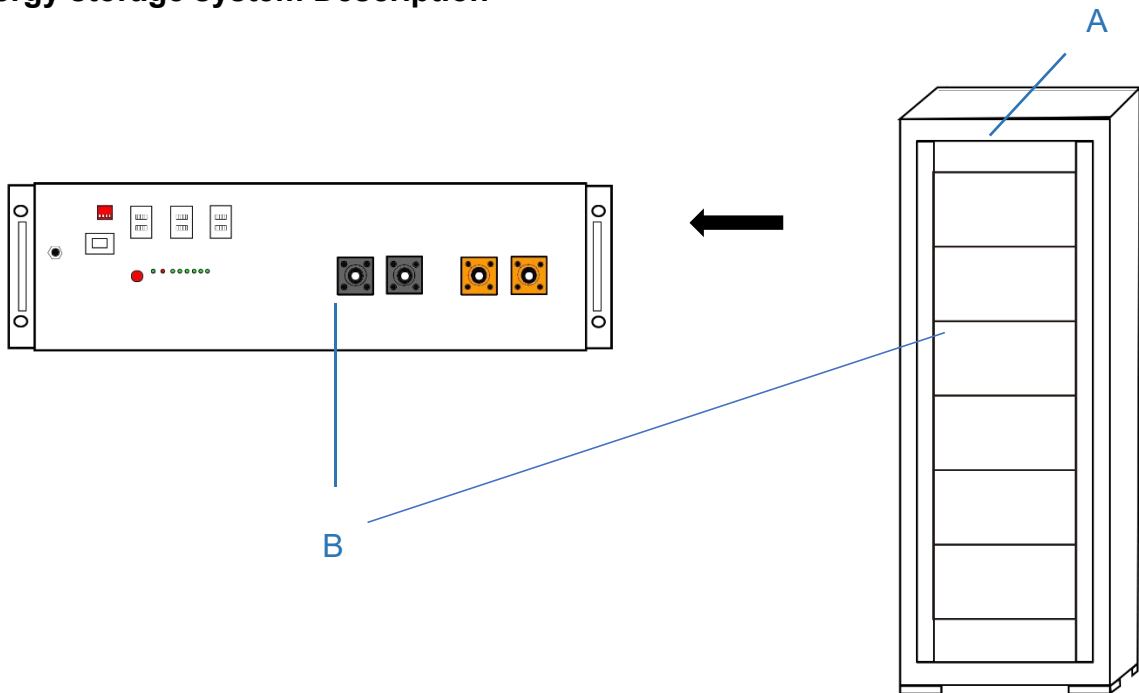

A	Box type cabinet
B	Connection area

One to six battery packs to parallel connection could be installed in one cabinet. **DIFFERENT CONNECTION CAN NOT BE INSTALLED IN ONE CABINET.**

NOTICE: "P" means parallel connection; "S" means series connection

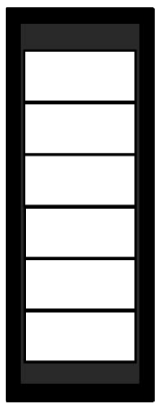

P
P
P

$1 \leq N \leq 6$



S
S
S

$3 \leq N \leq 8$









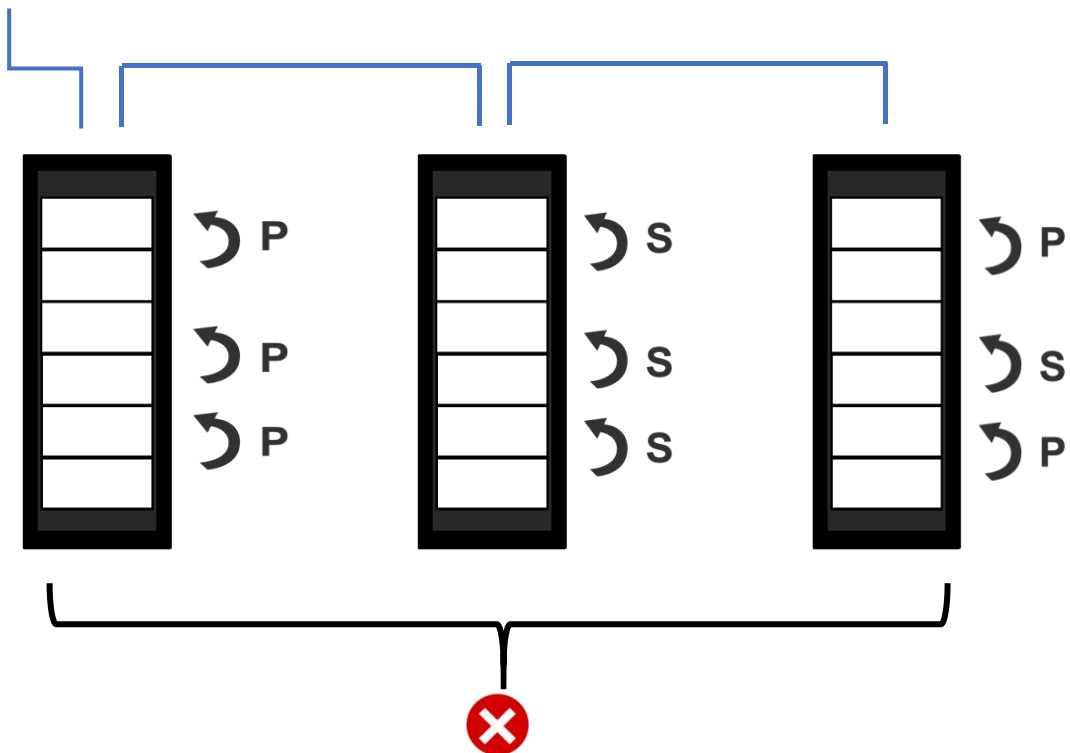
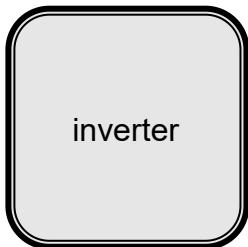

P
S
P





Maximum fifteen battery cabinets could be connected in parallel.



3.2 Symbol on the system

Symbol	Explanation
	<p>Observe the documents Observe all documents supplied with the system</p>
	<p>Grounding conductor This symbol indicates the position for connecting a grounding conductor</p>
	<p>Disposal Do not dispose of the system together with household waste.</p>
	<p>CE marking The system complies with the requirements of the applicable EU directives.</p>
	<p>Place it straight up, without inclination or upside down.</p>
	<p>Handle with care</p>
	<p>Keep it dry</p>
	<p>Keep the battery packs away from open flame or ignition sources.</p>
	<p>Beware of electrical voltage.</p>

	<p>Beware of a danger zone</p> <p>This symbol indicates that the system must be additionally grounded if additional grounding or equipotential bonding is required at the installation site.</p>
	<p>Keep the battery packs away from children.</p>
	<p>Do not short circuit.</p>

4. Installation

4.1 Requirements for Installation

4.1.1 Requirements for Installation Location



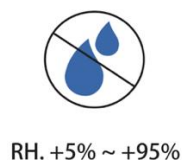

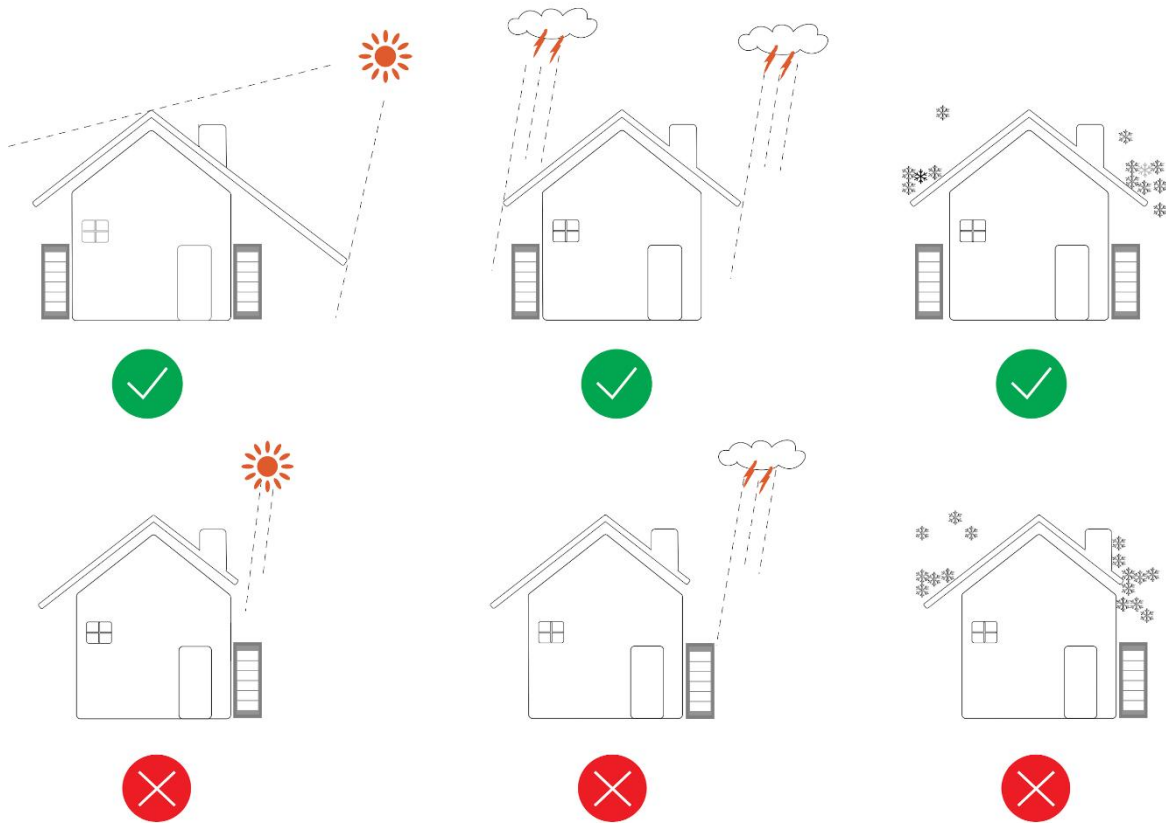



- a) A solid support surface must be available (e.g., concrete or masonry).
- b) The installation location must be inaccessible to children.
- c) The installation location must be suitable for the weight and dimensions of the energy storage system.
- d) The installation location must not be exposed to direct solar irradiation.
- e) The installation location must not be close to the fire.
- f) The altitude of the installation location should be less than 3000m.
- g) The ambient temperature should be between -10°C and +50°C.
- h) The ambient humidity should be between 5-95%.



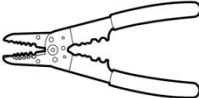
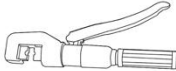

4.1.2 Installation Tools

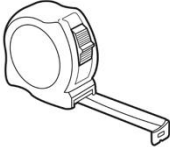
The tools in the following table could be needed during the installation.

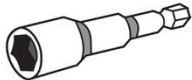
				
Network Wire Clamp	Pen	Phillips Screwdriver Bit	Flat-Head Screwdriver	Torque Wrench
				
Wire Stripper	Crimping Pliers	Wrench	Tape Measure	Drill
				
Hair Dryer	Cylinder Screwdriver			

4.1.3 Safety Gear

Wear the following safety gear when dealing with the energy storage system.



Insulated gloves



Safety goggles



Safety shoes

4.2 Installation

⚠ QUALIFIED PERSON

⚠ DANGER

Danger to life from electric shock due to live DC cables or connectors at the energy storage system

The DC cables connected to the energy storage system may be live. Touching the DC conductors or the live components leads to lethal electric shocks.

- Do not touch non-insulated cable ends.

⚠ CAUTION

Risk of injury due to weight of the battery pack

Injuries may result if the battery pack is lifted incorrectly or dropped while being transported or installed.

- Transport and lift the battery pack carefully. Take the weight of the battery pack into account.
- Wear suitable personal protective equipment for all work on the energy storage system.

NOTE

Damage to the energy storage system due to under voltages

- If the battery is installed, it should be set into operation within a month, or checked regularly, otherwise there might be damage to the batteries.

5. Electrical Connection

5.1 Overview of the Connection Area

5.1.1 Connection Area View

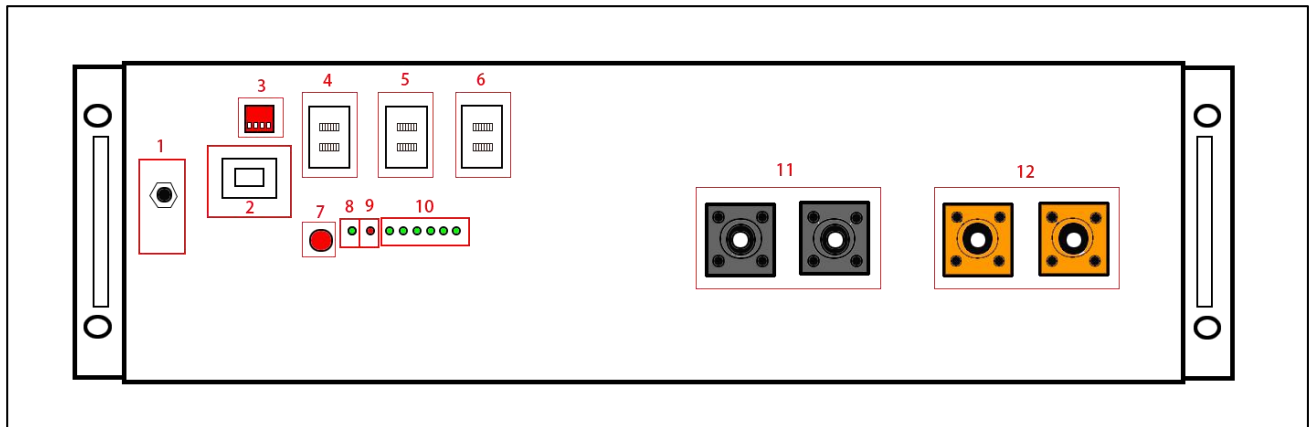

1	Grounding point
2	Power switch
3	ADD
4	Dry contact / console
5	A/B RS485
6	Link port 0/1
7	Start
8	Run
9	Alarm
10	SOC
11	-Power terminal
12	+Power terminal

5.2 Connection diagram

5.2.1 One Battery Cabinet

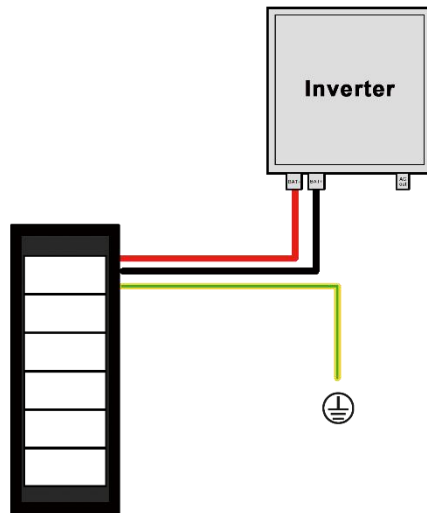

NOTICE

1. The two cables connecting the battery cabinet and the inverter must be of equal length.
2. Connecting wire specification: 8 AWG
3. The total length of power cable between each battery cabinet and the inverter should be less than 20 meters.

5.2.2 Two Battery Cabinets

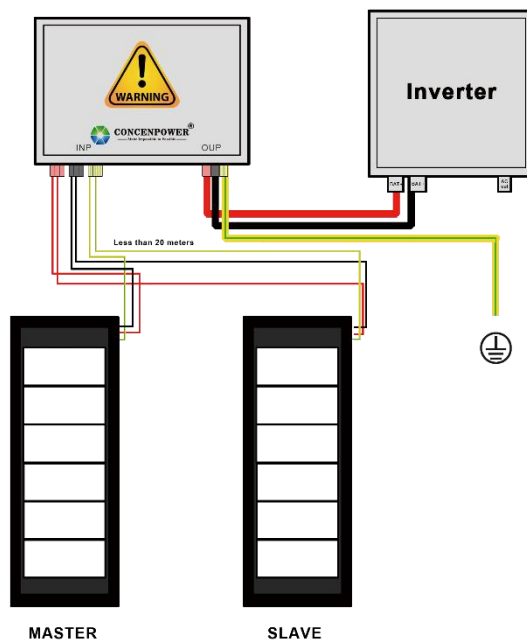

NOTICE

1. The two sets of cables connecting battery cabinet and the wire combiner must be of equal length.
2. The length of the power cables from inverter to the combiner box should be same.
3. Connecting wire specification: 8 AWG
4. The total length of power cable between each battery cabinet and the inverter should be less than 20 meters.
5. If the combiner box is not used, the parallel connection device should meet the following requirements.
 - a) No less than IP 55 for the outdoor use.
 - b) Maximum Operating Voltage, 1000V DC
 - c) Maximum Output Current, 40A DC
 - d) Breaking Current, 40A DC.

5.2.3 Three Battery Cabinets

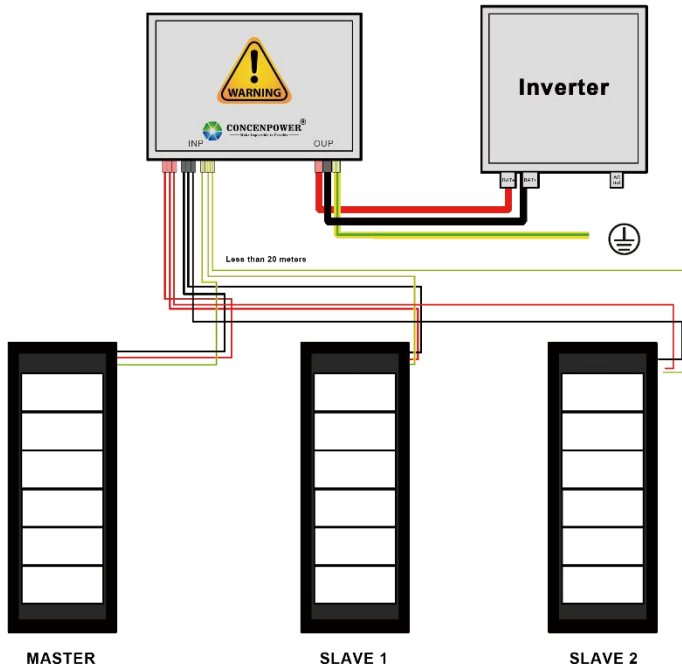

NOTICE

1. The three sets of cables connecting the battery cabinet and the inverter must be of equal length.
2. The length of the power cables to the combiner box should be same.
3. Connecting wire specification: 8 AWG
4. The total length of power cable between each battery cabinet and the inverter should be less than 20 meters.
5. If the combiner box is not used, the parallel connection device should meet the following requirements.
 - a) No less than IP 55 for the outdoor use.
 - b) Maximum Operating Voltage, 1000V DC
 - c) Maximum Output Current, 40A DC

5.3 DC Connection

⚠ DANGER

Danger to life from electric shock due to live DC cables or conductors at the energy storage system. The DC cables connected to the energy storage system may be live. Touching the DC conductors or the live components leads to lethal electric shocks.

- Do not touch non-insulated cable ends.

When two or three battery cabinets are connected, the positive power cable length of all the energy storage systems should be approximately equal, and so are the negative power cables. A junction box or Y-Bridge connectors are needed to combine these cables. You can refer to CONCENPOWER Combiner Box, which is available at our website. Please also follow the local, state, provincial, federal, or national laws, regulations, and instructions from the inverter manufacturer to choose the right junction box or Y-Bridge connectors.

6. Commission

6.1 Switching on the energy storage system

⚠ QUALIFIED PERSON

Requirements:

- The power cable connection between the battery cabinets and the inverter (if any) is switched off.
- The inverter (if any) must be correctly mounted.
- All cables must be correctly connected.

Switch on energy storage system (one cabinet)

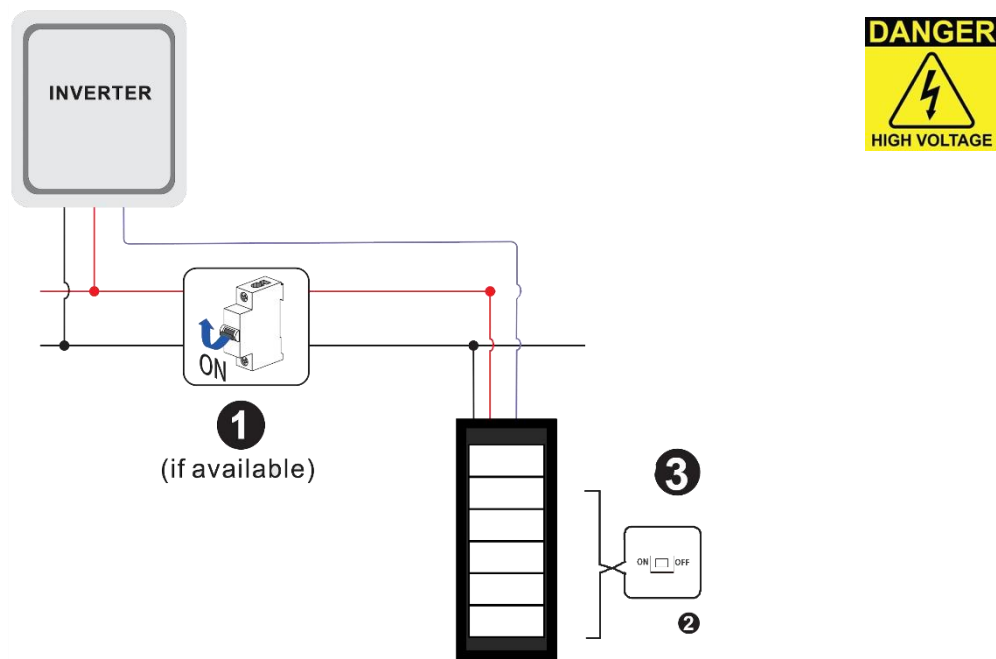

1. Turn on the air switch between the battery and inverter if there is any.
2. Push up the air switch of each battery pack to On.
3. Push up the air switch of the BMU to On
4. Press the “ON/OFF” button on the BMU communication area.
5. The device beeps and the display panel begin to show content, which means the energy storage system is ready to work.

If it is failed to switch on the energy storage system, read Chapter 12 Troubleshooting and also the Service Guideline and Checklist. IF THE PROBLEM STILL CANNOT BE SOLVED, CONTACT

CONCENPOWER Co., Ltd.

OUR LOCAL AFTER-SALE SERVICE WITHIN 48 HOURS.

Switch on energy storage system (two or more cabinets)

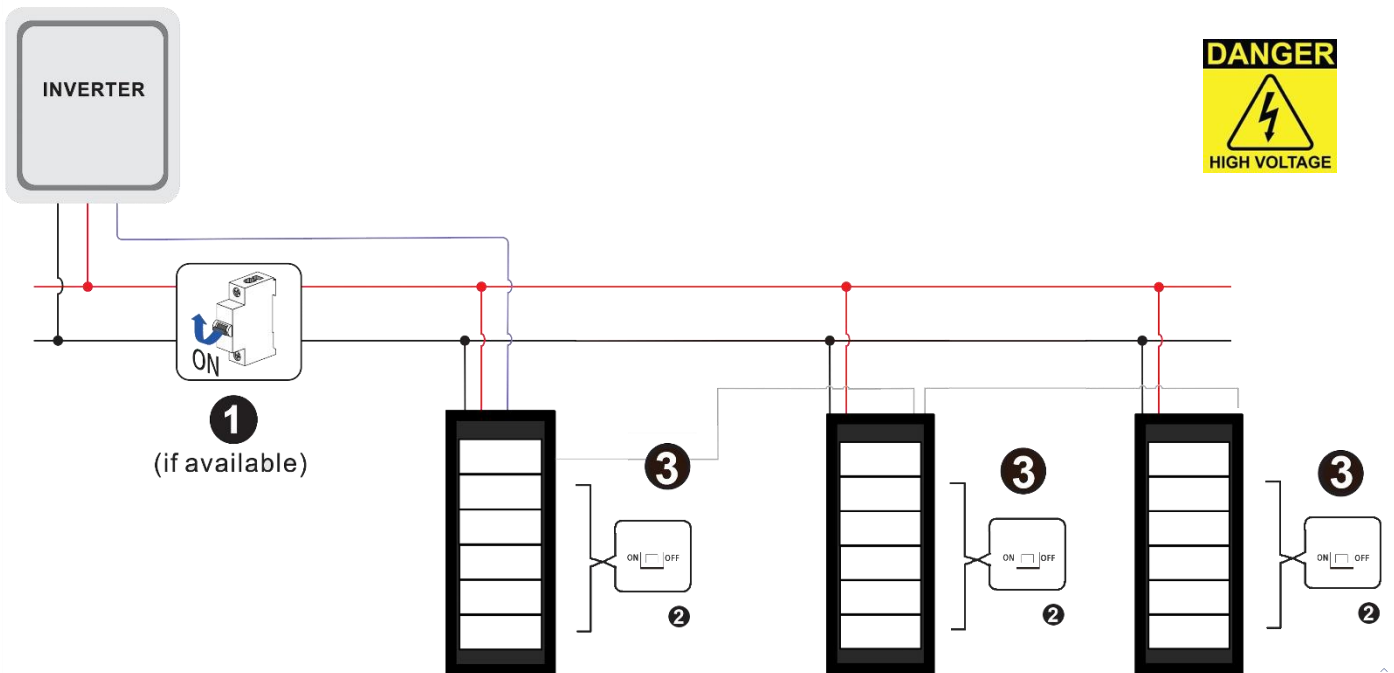

1. Turn on the air switch between the battery and inverter if there is any.
2. Push up the air switch of each battery pack of each cabinet to On.
3. Push up the air switch of each BMU to On.
4. Press the ON/OFF button of the master cabinet BMU.
5. The device emits a “beep” sound, and the display starts to show content, which means the energy storage system is ready to work.
6. If it is failed to switch on the energy storage system, read Chapter 12 Troubleshooting and also the Service Guideline and Checklist. IF THE PROBLEM STILL CANNOT BE SOLVED, CONTACT OUR LOCAL AFTER-SALE SERVICE WITHIN 48 HOURS.

6.2 Switch on and Commission inverter

The procedures of on-grid and off-grid applications is the same.

The procedure is:

1. Mount and connect the inverter according to the inverter manufacturer’s instruction.
2. Commission and configure the inverter according to the inverter manufacturer’s instruction (RS485-3 used to communicate with inverter).

If the battery information could be read correctly, it means the connection between the energy storage system and the inverter is all right.

If the energy storage system is operating normally, but the inverter still cannot read the information of the energy storage system, go to the Chapter 12 Troubleshooting of this manual and also read the Service Guideline and Checklist.

6.3 Switching on the Energy Storage System (with inverter)

To make sure the energy storage system can work well with the inverter, please follow the right procedure to start them. The procedure is:

- 1) Turn on the switch between the inverter and battery if there is any.
- 2) Push up each battery pack air switch of each cabinet to On.
- 3) Push up each BMU air switch to On.
- 4) Press ON/OFF button on the BMU communication area (If more than two battery cabinets, press the ON/OFF button of Master BMU only). When the Beep sound is heard, the system is powered on and the display is on.
- 5) Switch on the inverter.

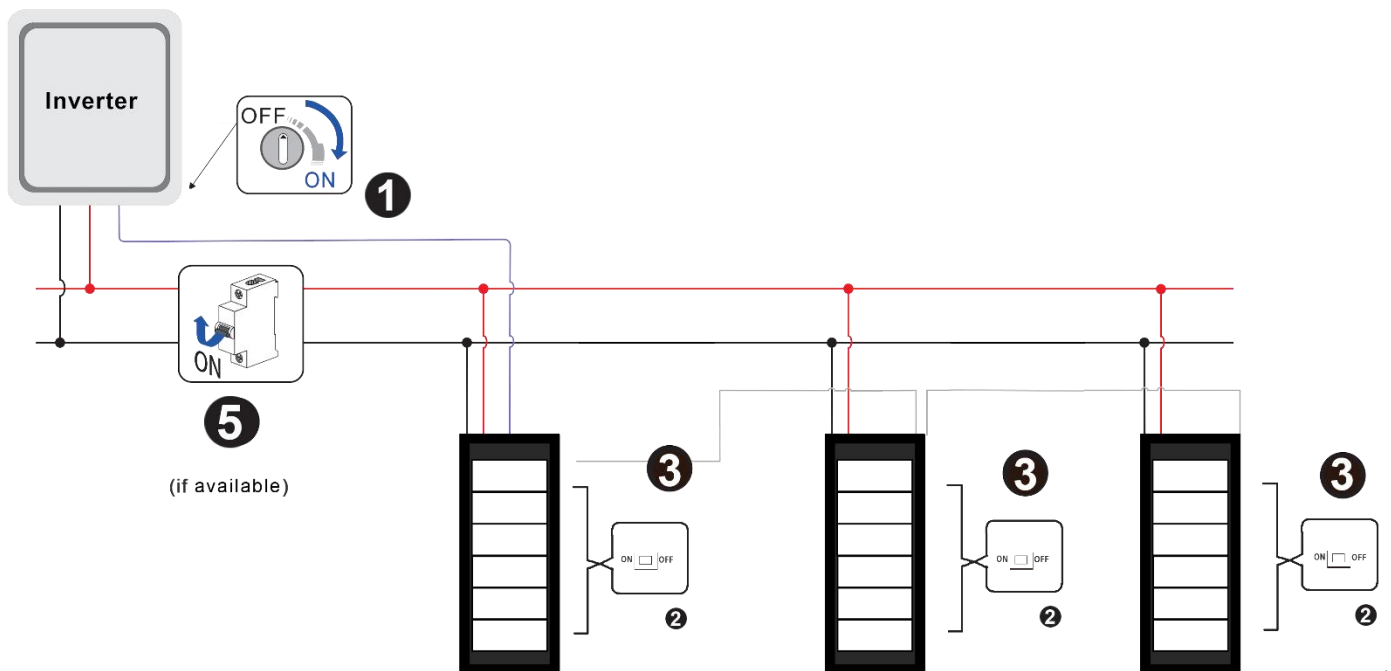

7. Decommissioning

⚠ QUALIFIED PERSON

⚠ DANGER

Danger to life from electric shock due to live DC cables or conductors at the energy storage system. The DC cables connected to the energy storage system may be live. Touching the DC conductors or the live components leads to lethal electric shocks.

- Do not touch non-insulated cable ends.

⚠ CAUTION

Risk of injury due to weight of the battery pack.

Injuries may result if the battery pack is lifted incorrectly or dropped while being transported or installed.

- Transport and lift the battery pack carefully. Take the weight of the battery pack into account.
- Wear suitable personal protective equipment for all work on the energy storage system.

7.1 Switching off the Energy Storage System (with inverter)

- 1) Switch off the inverter.
- 2) Press ON/OFF button on the BMU communication area for 3 seconds (If more than two battery cabinets, press the ON/OFF button of Master BMU only). When the “Beep” sound is heard, the system is powered off and the display is turned off.
- 3) Push down each BMU air switch to off.
- 4) Push down the air switch of each battery pack of all cabinets to off.
- 5) Turn off the air switch between the energy storage system and the inverter if there is any.

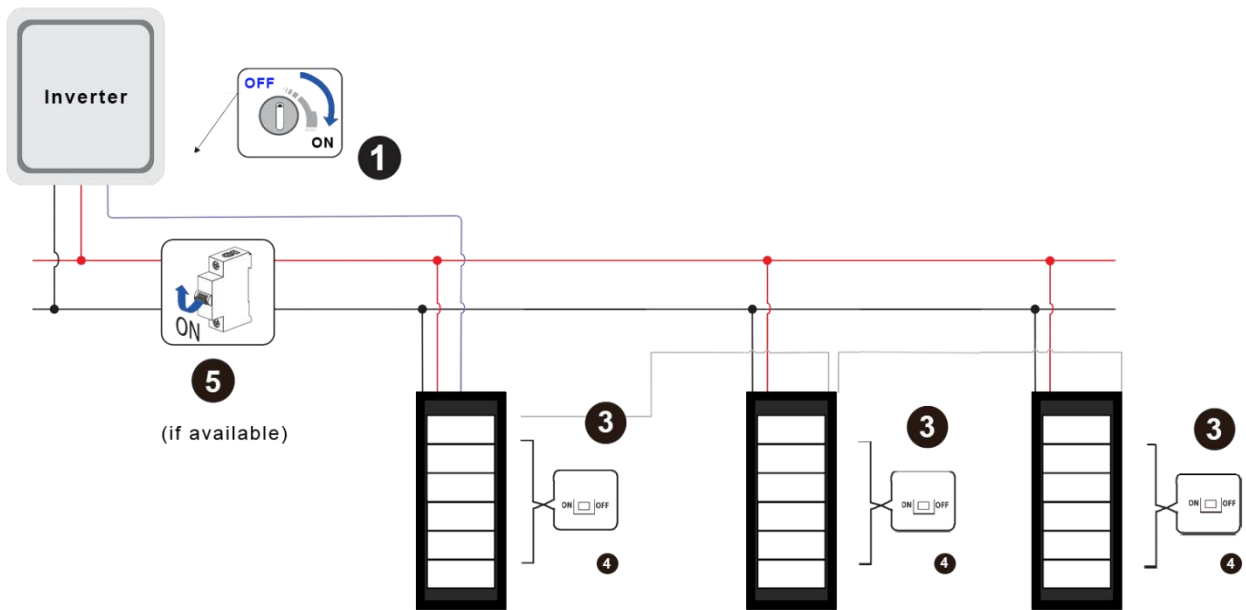

7.2 The whole procedure of decommissioning

1. Switch off the inverter.
2. Press ON/OFF button on the BMU communication area for 3 seconds. (If more than two battery cabinets, press the ON/OFF button of Master BMU only)
3. Turn off all air switches of energy storage system.
4. Switch off the breaker between the inverter and the energy storage system if there is any.
5. Loosen cable glands and remove the cover of BMU.
6. Remove output positive and negative cables of BMU.
7. Remove all covers of the energy storage system.
8. Remove all cables from the energy storage system.
9. Loosen the screws on hangers between BMU and the wall. And then take off the hangers.
10. Tighten the nuts on the cable glands on the BMU cover.
11. Remove the screws connecting the BMU, battery packs and base.
12. Take the BMU from battery pack and battery packs from the base.
13. Before lifting the battery pack, ensure that the screws on both sides of them are removed.
14. Remove the hangers (BMU part).
15. If the energy storage system is to be stored or shipped, pack the system. Use the original packaging or packaging that is suitable for the weight and dimensions of the system.

16. Dispose of the energy storage system in accordance with the locally applicable battery disposal regulations.

8. Extension

8.1 Extension Battery Pack

QUALIFIED PERSON

DANGER

Danger to life from electric shock due to live positive and negative terminals or conductors at the battery pack. The positive and negative terminal connected to the battery pack may be live. Touching the terminals or the live components leads to lethal electric shocks.

- Do not touch non-insulated terminal ends.

CAUTION

Risk of injury due to weight of the battery pack.

Injuries may result if the battery pack is lifted incorrectly or dropped while being transported or installed.

- Transport and lift the battery pack carefully. Take the weight of the battery pack into account.
- Wear suitable personal protective equipment for all work on the energy storage system.

Before that, it is necessary to check whether the new battery pack is operating normally as follows:

1. Turn on the air switch of the battery pack;
2. Press the battery pack ON/OFF button;
3. Measure whether the battery pack voltage is within the normal working voltage range.

Procedure:

1. Check the parameters of the existing system through the screen.
2. Shut off the inverter.
3. Switch off the energy storage system.
4. Switch off the breaker between the inverter and the energy storage system if there is any.
5. Remove all cables connected on the cabinet BMU and take the BMU off.
6. Add the new pack on top of other battery packs.
7. Put the BMU back on top of the new battery pack.
8. Connect the new battery pack to original battery packs in parallel and reconnect all cables of

BMU. (Check connections and communication)

9. Configure the dial code, including connection mode and address code (part6.6).
10. Switch on the energy storage system.
11. Start the inverter.

Note: The newly added battery pack may have inaccurate SOC measurement. The system can accurately detect the SOC only after the overall energy storage system has undergone a working cycle.

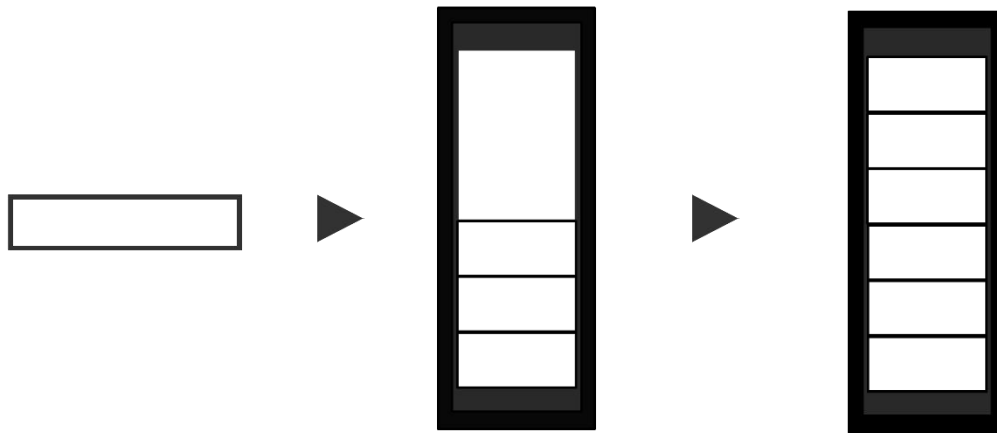

8.2 Extension Battery Cabinet

⚠ QUALIFIED PERSON

⚠ DANGER

Danger to life from electric shock due to live DC cables or conductors at the energy storage system. The DC cables connected to the energy storage system may be live. Touching the DC conductors or the live components leads to lethal electric shocks.

- Do not touch non-insulated cable ends.

⚠ CAUTION

Risk of injury due to weight of the battery pack.

Injuries may result if the battery pack is lifted incorrectly or dropped while being transported or installed.

- Transport and lift the battery pack carefully. Take the weight of the battery pack into account.
- Wear suitable personal protective equipment for all work on the energy storage system.

The number of battery packs contained in the new parallel battery cabinet should be the same as the number of battery packs contained in the original system.

Before that, it is necessary to check whether the new battery pack is operating normally as the steps mentioned in section 9.1.

Procedure:

1. Check the parameters of the existing system through the screen.
2. Shut off the inverter.
3. Switch off the energy storage system.
4. Switch off the breaker between the inverter and the energy storage system if there is any.
5. Refer to the section 4.2, fix and install the newly added battery cabinet.
6. Connecting new battery cabinets to original system in parallel. This step may use wire combiner box.
7. Configure the dial code, including connection mode and address code (part6.6).
8. Switch on the energy storage system.
9. Start the inverter.

Note: The newly added battery cabinet may have inaccurate SOC measurement. The system can accurately detect the SOC only after the overall energy storage system has undergone a working cycle.

9. Troubleshooting

Please also see the CONCENPOWER Service Guideline and Checklist for troubleshooting. The latest version is available at our website www.concenpower.com.

9.1 Energy storage system Behavior under Fault Conditions

Error shows on BMU screen

The type of fault that has occurred is shown on the display of the energy storage system. Any system shutdown caused by any failure will cause the device to sound an alarm. If you hear an alarm sound, please confirm the type of failure in time, shut down the system and contact after-sales service.

The clicking sound when the system is turned on is not a malfunction. Typically, there will be several clicks for the number of battery cabinets the system contains.

NOTE

Damage to the energy storage system due to under voltages

- If the battery is installed, it should be set into operation within a month, or checked regularly, otherwise there might be damage to the batteries.

9.2 Inverter cannot Detect Battery Information

When the energy storage system is connected to the inverter, the inverter cannot detect the battery information, the possible reasons are as follows:

1. The communication line between the inverter and the energy storage system is not connected properly
2. The inverter manufacturer has not established a communication protocol with CONCENPOWER. Please refer to the parameter table of the inverter, and set the corresponding parameters according to the "lead-acid battery" mode of the inverter

9.3 Error Event

No.	Name	Solution
1	Over voltage protection (OVP)	The problem may be caused by charging the energy storage system. Turn off the charging of the system, wait for the system voltage to return to normal, and then the protection will be automatically released. Test the voltage of each battery pack (Service Guideline and Checklist Part 4.2)
2	Under voltage protection (UVP)	Shut down the system quickly to avoid further discharge. Check whether the system can shut down normally (by pressing the master BMU ON/OFF button for 3s). - If the system cannot shut down normally, lift the BMU. Avoid further discharge of the battery, by searching the problem while the battery is completely off / BMU is lifted. Do not turn on the battery before making sure the inverter should be able to charge the battery. Test the voltage of each battery pack (Service Guideline and Checklist Part 4.2)
3	Over current protection	Shut down the output of system. Wait for the system current to return to normal and the protection will be released automatically

	(OCP)	
4	Over temperature protection (OTP)	Shut down the system quickly to avoid further operating. Wait for the system temperature to return to normal and the protection will be released automatically
5	Under temperature protection (UTP)	The ambient temperature (more information on parameter sheet) of the system is too low, please adjust the ambient temperature.

10. Maintenance and Storage

Cleaning

It is recommended that the energy storage system be cleaned periodically. If the enclosure is dirty, please use a soft, dry brush or a dust collector to remove the dust. Liquids such as solvents, abrasives, or corrosive liquids should not be used to clean the enclosure.

Maintenance

The battery pack should be stored in an environment with a temperature range between -10°C ~ $+50^{\circ}\text{C}$, and charged regularly according to the table below with no more than 0.5 C (C-rate is a measure of the rate at which a battery is discharged relative to its maximum capacity.) to the SOC of 30% after a long time of storage.

Storage environment temperature	Relative humidity of the storage environment	Storage time	SOC
Below -10°C	/	Not allowed	/
$-10\sim 25^{\circ}\text{C}$	5%~70%	≤ 12 months	$25\%\leq\text{SOC}\leq 60\%$
$25\sim 35^{\circ}\text{C}$	5%~70%	≤ 6 months	$25\%\leq\text{SOC}\leq 60\%$
$35\sim 50^{\circ}\text{C}$	5%~70%	≤ 3 months	$25\%\leq\text{SOC}\leq 60\%$
Above 50°C	/	Not allowed	/

NOTE

Damage to the system due to under voltages

- Charge the over-discharged system within seven days when the temperature is above 25°C.
- Charge the over-discharged system within fifteen days when the temperature is below 25° C.

11. Disposal of Energy storage system

Disposal of the system must comply with the local applicable disposal regulations for electronic waste and used batteries.

- Do not dispose of the energy storage system with your household waste.
- Avoid exposing the batteries to high temperatures or direct sunlight.
- Avoid exposing the batteries to high humidity or corrosive atmospheres.
- For more information or arrange a collection please contact CONCENPOWER Service Partner (see contact details at the bottom of this document).

12. Technical Data

12.1 5 CON-LVS

Battery Package	Rack-mounted Battery Package (5kWh, 51.2V, 65Kg)					
Number of Packages	1	2	3	4	5	6
Usable Capacity	5kWh	10kWh	15kWh	20kWh	25kWh	30kWh
Cont. Output Current	52A	104A	104A	104A	104A	104A
Peak Output Current	90A,1s	180A,1s	180A,1s	180A,1s	180A,1s	180A,1s
Nominal Voltage	51.2V	51.2V	51.2V	51.2V	51.2V	51.2V
Operating Voltage	40~58.4V	40~58.4V	40~58.4V	40~58.4V	40~58.4V	40~58.4V
Dimensions (H/W/D) (mm)	490* 700*435	680* 700*435	870* 700*435	1060* 700*435	1250* 700*435	1440* 700*435

Operating Temperature -10°C~50°C

Battery Type Lithium iron phosphate Battery (LiFePO4)

CONCENPOWER Co., Ltd.

Communication

RS485, CAN

Enclose Protection Rating

IP55

Round-trip Efficiency

≥ 95%

Applications

OFF grid (Backup) / ON Grind + OFF Grid (Backup)

1: Test conditions: 25 °C, 100 % depth of discharge (DOD), 1C charge& 1.5C discharge

2: Refer to battery warranty letter for conditional application

12.2 10 CON-LVS

Battery Package	Rack-mounted Battery Package (10 kWh, 51.2V, 135Kg)					
Number of Packages	1	2	3	4	5	6
Usable Capacity	10 kWh	20 kWh	30 kWh	40 kWh	50 kWh	60 kWh
Cont. Output Current	52A	104A	104A	104A	104A	104A
Peak Output Current	180A,1s	180A,1s	180A,1s	180A,1s	180A,1s	180A,1s
Nominal Voltage	51.2V	51.2V	51.2V	51.2V	51.2V	51.2V
Operating Voltage	40~58.4V	40~58.4V	40~58.4V	40~58.4V	40~58.4V	40~58.4V
Dimensions (H/W/D) (mm)	565* 700*435	830* 700*435	1095* 700*435	1360* 700*435	1625* 700*435	1890* 700*435

Operating Temperature

-10°C~50°C

Battery Type

Lithium iron phosphate Battery (LiFePO4)

Communication

RS485, CAN

Enclose Protection Rating

IP55

Round-trip Efficiency

≥ 95%

Applications

OFF grid (Backup) / ON Grind + OFF Grid (Backup)

1: Test conditions: 25 °C, 100 % depth of discharge (DOD), 1C charge& 1.5C discharge

2: Refer to battery warranty letter for conditional application

13. Contact Information

Note: Please also see the CONCENPOWER Rack-mounted energy storage system Service Guideline and Checklist Service Guideline and Checklist for troubleshooting. The latest version is available at our website www.concenpower.com.

CONCENPOWER Global Service	
Official services link	Social media link
www.concenpower.com	https:// www.facebook.com/ CONCENPOWER
E-mail: techsupport.yang@concenpower.com /nevaehdu@concenpower.com	https://twitter.com/ CONCENPOWER
www.concenpower.com	https://www.linkedin.com/company/concenpower
Address: A2-A, Electricity Information Industrial Park, High-tech 7 Rd., Gaoxin District, Rizhao, Shandong, China (Mainland)	