

# Industry Energy storage system



A single battery cabinet is composed of 8 battery packs connected in series, with a voltage of 409.6V. A single battery cabinet can support a 3-phase inverter. In addition, 1 to 16 battery cabinets can be directly connected in parallel, and the capacity of a single cabinet can reach 80 kWh to 114 kWh.

## Automatic switching of two-way mode

1. Automatically detect the operation of the system. When the battery is exhausted, it automatically switches to AC mains mode.
2. Built-in timer, you can set the operating time of different working modes independently.

## Multiple input modes

1. Suitable for hybrid energy storage such as Solar, diesel, and wind power
2. Off-grid energy storage

## Support the use of high-power mechanical equipment

1. The use of industrial frequency inverter can support the use of high-power industrial and commercial equipment.
2. Strong overload capacity, can withstand the instantaneous high current release when large equipment is started.

## Large-capacity grid energy storage system

1. Expandable energy storage solution.
2. Customized design based on customer requirements.
3. Applicable to large-capacity energy storage system occasions.

## Application scenario

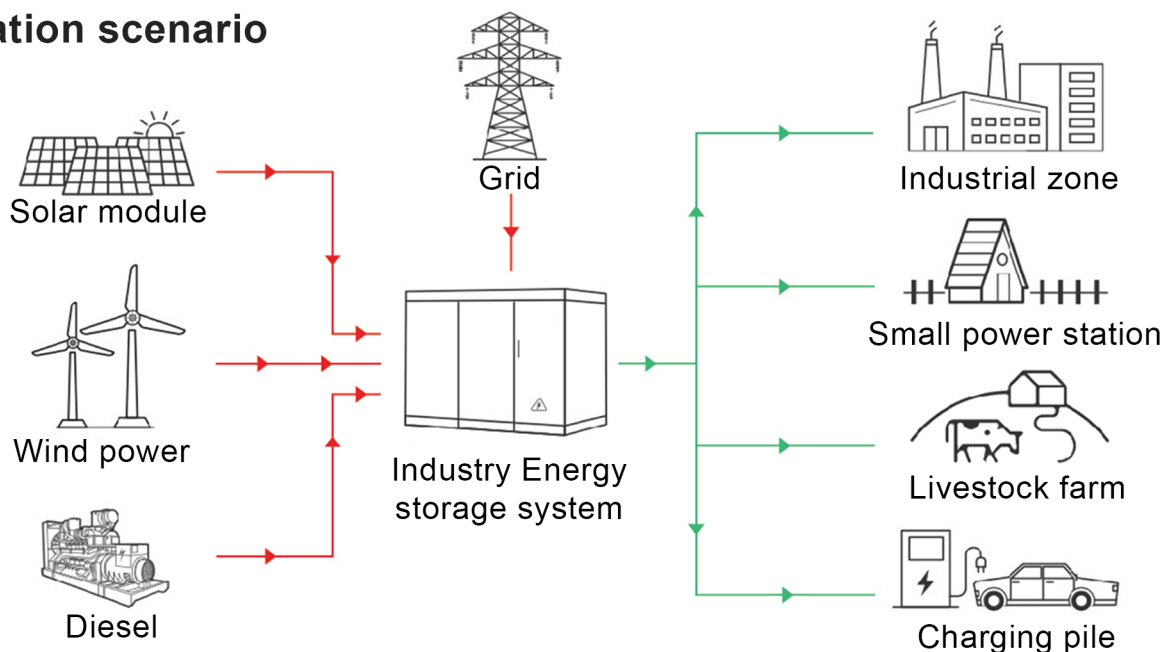

# Parameters

Model	CIC20	CIC30	CIC40	CIC50	CIC60	CIC80	CIC100
<b>Inverter parameters</b>							
Inverter power	20KVA	30KVA	40KVA	50KVA	60KVA	80KVA	100KVA
Inverter type	Industry frequency inverter						
Phase	3 phase+N+G						
AC input range	380Vac ± 20%						
Frequency range	45Hz~55Hz						
Output voltage	Battery mode:380Vac ± 3%;AC mode:380Vac ± 20%						
Frequency range (ACs mode)	45Hz~55Hz						
Frequency range (Battery mode)	50Hz ± 0.1Hz						
Overload (AC mode)	AC mode (100%~110%: 10 minutes; 110%~130%: 1 minute; >130%: 1 second)						
Overload (Battery mode)	Battery mode (100%~110%: 30 seconds; 110%~130%: 10 seconds; >130%: 1 second)						
Current peak ratio	3: 1 max						
Total harmonic distortion	Linear load <3%; non-linear load						
Balanced load voltage	< ± 1%						
Unbalanced load voltage	< ± 5%						
Switching time	<10ms						
Waveform	Pure sine wave						
Maximum efficiency	85%						
Noise	<58dB (1m distance)						
Load monitoring	Yes						
<b>PV input MPPT</b>							
System voltage	384V						
Rated current	100A						250A
Charging mode	MPPT automatic maximum power point tracking						
Startup time	≤10s						
Dynamic response recovery time	≤500us						
Static power consumption	≤2W						
Overall efficiency	≥96.5%						
MPPT working voltage range	384V: DC450V-750V;						

Maximum PV input power	36kW						
<b>Battery parameters</b>							
Battery type	Lithium iron phosphate Battery(LiFePO4)						
Battery cabinet capacity	114.4kWh (Single battery cabinet)						
Battery nominal voltage	409.6V						
Working voltage range	320~467.2V						
Continuous output current	120A						
Peak output current	150A,1s						
Working temperature range	-10℃~50℃						
<b>General parameters</b>							
Model	CIC20	CIC30	CIC40	CIC50	CIC60	CIC80	CIC100
Working temperature range	0~40℃						
Working altitude	<95% and no condensation						
Working relative humidity	<1000m (power decreases by 1% for every 100m increase, up to 5000m)						
External communication	RS485 + CAN						
Grid regulation	Yes						
Safety supervision	Yes						
Waterproof device	Yes						
Surge protection device	Yes						
Protection level	IP65						
Protection	Input polarity reverse protection; output polarity reverse protection; high voltage protection; low voltage protection; short circuit protection; over temperature protection						
Cooling device	Air-cooled						
Fire protection device	Aerosol						
Application area	Off-grid (backup)						
Dimensions (L*W*H m)	2.437*1*1.824						
Weight (Kg)	1616.1	1676.1	1726.1	1776.1	1896.1	1976.1	2276.5